

LAIPAC TECH GPS MODULE

PG-11A Specifications Sheet

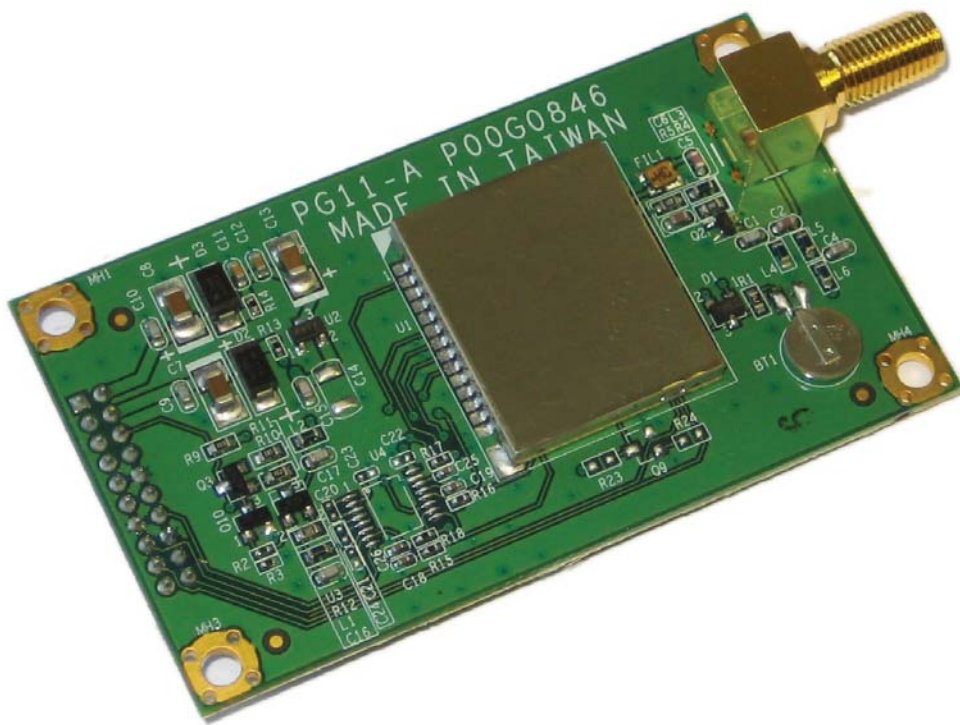

- ▶ SiRF Staff III Low Power Single Chipset
- ▶ 40.64 x 71.12 x 1.4mm (1.6 x 2.8 x 0.5")
- ▶ TTFH (C/W/H) : 42 / 38 / 1 sec.
- ▶ RoHS Compliance

1. Introduction

The Laipac PG-11A module is high performance, low power, 20-channel TTL level GPS receiver, based on the SiRFStarIII/LP single chipset technology while providing fast time-to-first-fix. Its far reaching capability meets the sensitivity requirements of car navigation as well as other location-based applications. The Laipac PG-11A module is designed to allow quick and easy integration into GPS-related applications, especially for compact size devices, such as:

- ▶ Fleet Management / Asset Tracking
- ▶ AVL and Location-Based Services

1.1. Features

Hardware and Software

- ▶ Based on the high performance features of the SiRF Star III low power single chipset.
- ▶ Dimensions: 40.64 x 71.12 x 1.4 mm (*1.6 x 2.8 x 0.5 inch*)
- ▶ RoHS compliant (lead-free)

Performance

- ▶ Cold/Warm/Hot Start Time: 42 / 38 / 1 sec. at open sky and stationary.
- ▶ Reacquisition Time: 0.1 second

Interface

- ▶ DIP type pitch 2.0mm- 2x10 pin header.
- ▶ Protocol: NMEA-0183 compliant.
- ▶ Baud Rate: 4800 bps.
- ▶ Right Angle SMA RF connector

2. Specifications

Technical Specifications

Feature	Item	Description
Chipset	GSC3f/LP Series	SiRFstarIII/LP single chip technology
General	Frequency	L1, 1575.42 MHz
	C/A code	1.023 MHz chip rate
	Channels	20
Accuracy	Position	10 meters, 2D RMS 5 meters 2D RMS, WAAS corrected < 5meters(50%), DGPS corrected
	Velocity	0.1 meters/second
	Time	1 microsecond synchronized to GPS time
Datum	Default	WGS-84
Time to First Fix(TTFF) (Open Sky & Stationary Requirements)	Reacquisition	0.1 sec., average
	Hot start	1 sec., average typical TTFF
	Warm start	35 sec., average typical TTFF
	Cold start	42 sec., average typical TTFF
Dynamic Conditions	Altitude	18,000 meters (60,000 feet) max.
	Velocity	515 meters/second (1000 knots) max.
	Acceleration	4g, max.
Power	Main power input	3.3 ~ 5.0 VDC
	Power consumption	≈250 mW (continuous mode)
	Supply Current	≈50mA @5.0 VDC
	Backup Power	2.0 ~ 5.0 VDC input.
Interface	Pin Header	DIP type pitch 2.0mm 2x10 pin header
	Protocol messages	NMEA-0183@4800 bps

Environmental Characteristics

Items	Description
Operating temperature range	-20 deg. C to + 60 deg. C
Storage temperature range	-55 deg. C to +100 deg. C

Physical Characteristics

Items	Description
Length	1.6 in / 40.64 mm
Width	2.8 in / 71.12 mm
Height	0.5in / 1.40 mm
Weight	16g (net)

3. Software

The Laipac PG-11A module includes GSW3.2.X series, the SiRF standard GPS software for SiRFstarIII low power single chipset receivers. Features include:

- ▶ Excellent sensitivity
- ▶ High configurability
- ▶ 1 Hz position update rate
- ▶ Supports use of satellite-based augmentation systems like the US WAAS or European EGNOS system (**Option**)
- ▶ Real-time Operating System (RTOS) friendly
- ▶ Capable of outputting either NMEA(default) or SiRF proprietary binary protocols
- ▶ Runs in full power operation (default) or optional power saving modes

Default configuration is as follows:

Item	Description
Core of firmware	SiRF GSW3.2.X
Baud rate	4800, 9600, 19200, 38400 or 57600 bps (default 4800)
Code type	NMEA-0183 ASCII
Datum	WGS-84
Protocol message	GGA(1sec), GSA(5sec), GSV(5sec), RMC(1sec), VTG(1sec)
Output frequency	1 Hz

Pin Assignment

Pin	Name	Type	Descriptions
1	ANT_PWR	I	Antenna Voltage (Note 1)
2	VCC_5V	I	+5.0 VDC Power Input (Note 2)
3	BAT	I	Backup Battery 2.0 ~ 5.0 VDC input.
4	VCC_3V	I	+3.3 VDC Power Input (Note 2)
5	PBRES	I	System Reset; Active Low
6	ANT_CHK	O	Active Antenna Check; High: Fail / Low: OK
7	Reserved		NC
8	Reserved		NC
9	Reserved		NC
10	GND		Ground
11	TXA	O	TTL Serial Data Output A
12	RXA	I	TTL Serial Data Input A
13	GND		Ground
14	TXB	O	TTL Serial Data Output B
15	RXB	I	TTL Serial Data Input B
16	GND		Ground
17	BOOTSEL	I	Booting Mode Select
18	GND		Ground
19	TIMEMARK	O	1 pulse per second Time Mark output (option)
20	Reserved		NC

Note:

- Pin 1 is the voltage for **external** active antenna. Either 3.3V or 5V, it should be same as the input voltage of the active antenna used.
- Pin 2 and Pin 4 are the optional power input pins. The customer should NOT provide both voltages (Pin 2 and Pin 4) at the same time.

4. Technical specifications

4.1. Block Diagram

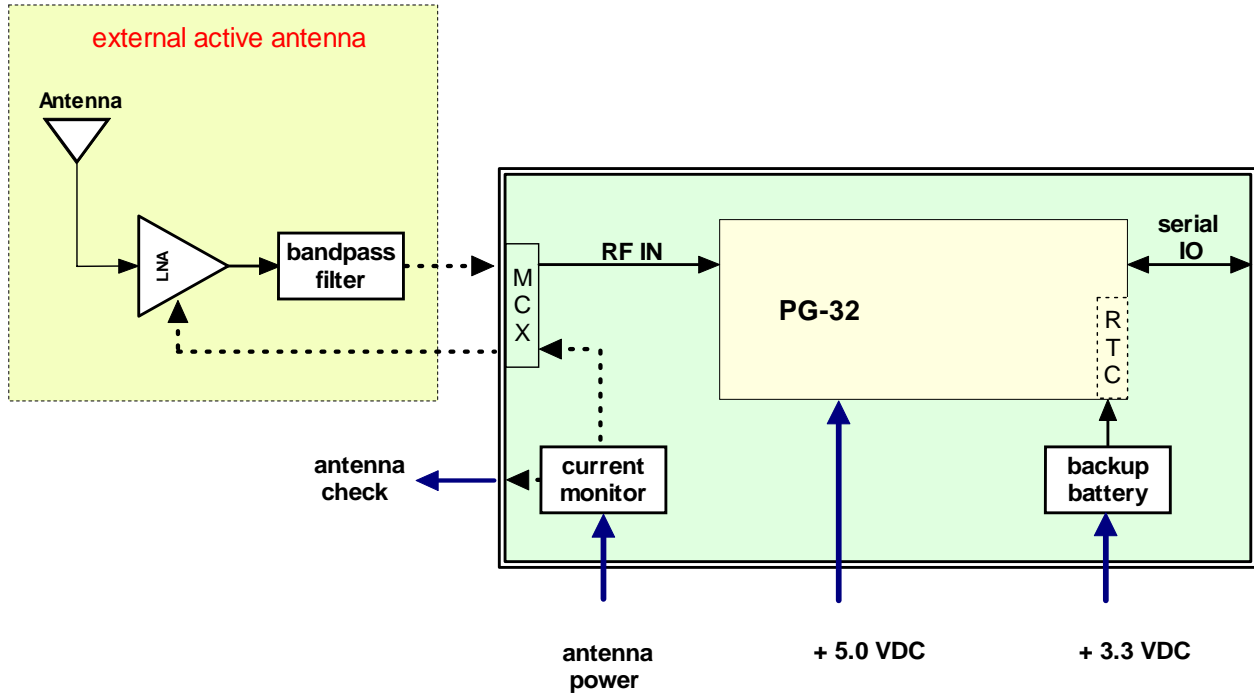

4.2. PCB Drawing (Unit : mm)

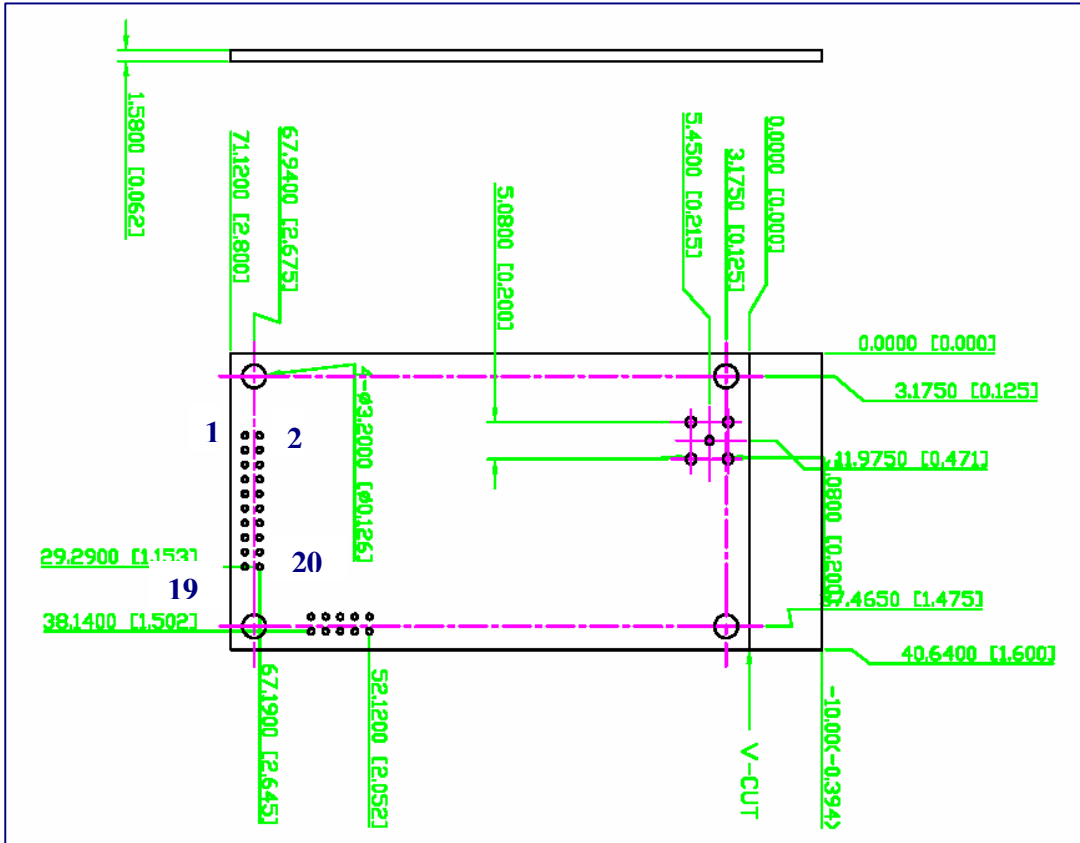

Specifications of 20-pin connector

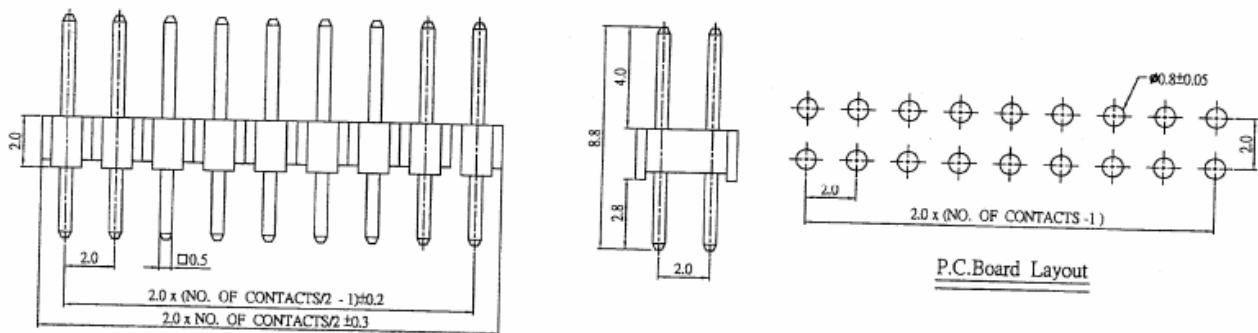

PIN	PIN DEFINITION	PIN	PIN DEFINITION
1	Antenna power	2	VCC_5V
3	VSTBY	4	VCC_3V
5	RESET	6	GPIO3
7	GPIO7	8	GPIO6
9	GPIO5	10	GND
11	TXA	12	RXA
13	GND	14	TXB
15	RXB	16	GND
17	BOOTSEL	18	GND
19	GPIO9	20	GPIO15

Outlook Image

