

TLP434A & RLP434A RF ASK Hybrid Modules for Radio Control (New Version)

TLP434A Ultra Small Transmitter

Easy-Link
Wireless

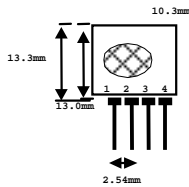

pin 1 : GND
pin 2 : Data In
pin 3 : Vcc
pin 4 : Antenna (RF output)

Frequency 315, 418 and 433.92 Mhz

Modulation : ASK
Operation Voltage : 2 - 12 VDC

RLP434A SAW Based Receiver

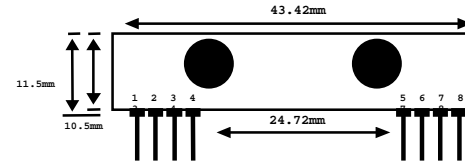

pin 1 : Gnd
pin 2 : Digital Data Output
pin 3 : Linear Output /Test
pin 4 : Vcc
pin 5 : Vcc
pin 6 : Gnd
pin 7 : Gnd
pin 8 : Antenna

Frequency 315, 418 and 433.92 Mhz

Modulation : ASK
Supply Voltage : 3.3 - 6.0 VDC
Output : Digital & Linear

Symbol	Parameter	Conditions	Min	Typ	Max	Unit
Vcc	Operating supply voltage		2.0	-	12.0	V
Icc 1	Peak Current (2V)		-	-	1.64	mA
Icc 2	Peak Current (12V)		-	-	19.4	mA
Vh	Input High Voltage	Idata= 100uA (High)	Vcc-0.5	Vcc	Vcc+0.5	V
VI	Input Low Voltage	Idata= 0 uA (Low)	-	-	0.3	V
FO	Absolute Frequency	315Mhz module	314.8	315	315.2	MHz
PO	RF Output Power- 50ohm	Vcc = 9V-12V	-	16	-	dBm
		Vcc = 5V-6V	-	14	-	dBm
DR	Data Rate	External Encoding	512	4.8K	200K	bps

Notes : (Case Temperature = 25°C +- 2°C , Test Load Impedance = 50 ohm)

Application Circuit :

Typical Key-chain Transmitter using HT12E-18DIP, a Binary 12 bit Encoder from Holtek Semiconductor Inc.

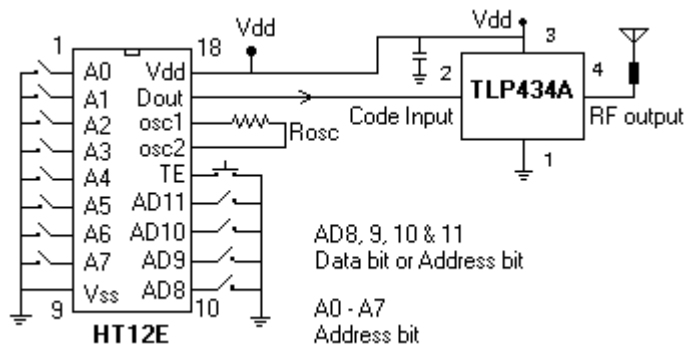

Laipac Technology, Inc.

50 West Beaver Creek Rd. Richmond Hill Ontario L4B 1G5 Canada
Tel: (905)762-1228 Fax: (905)763-1737 e-mail: info@laipac.com



Symbol	Parameter	Conditions	Min	Typ	Max	Unit
Vcc	Operating supply voltage		3.3	5.0V	6.0	V
Itot	Operating Current		-	4.5	-	mA
Vdata	Data Out	Idata = +200 uA (High)	Vcc-0.5	-	Vcc	V
		Idata = -10 uA (Low)	-	-	0.3	V

Electrical Characteristics					
Characteristics	SYM	Min	Typ	Max	Unit
Operation Radio Frequency	FC	315, 418 and 433.92			MHz
Sensitivity	Pref		-110		dBm
Channel Width			+500		Khz
Noise Equivalent BW			4		Khz
Receiver Turn On Time			5		ms
Operation Temperature	Top	-20	-	80	C
Baseboard Data Rate			4.8		KHz

Application Circuit :

Typical RF Receiver using HT12D-18DIP, a Binary 12 bit Decoder with 8 bit uC HT48RXX from Holtek Semiconductor Inc.

